

# SHEARBUTTON

TOOL CODE S1

30

ORDERING SPECIFICATIONS

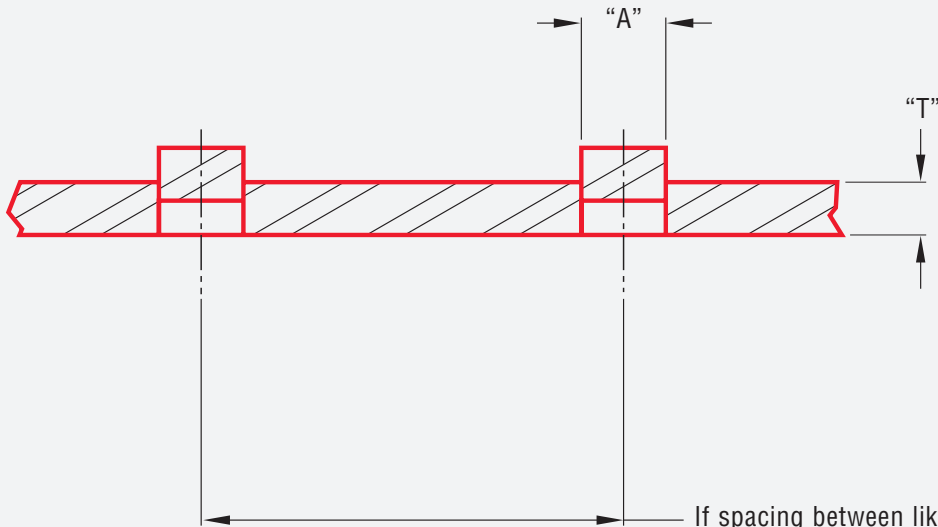

If spacing between like or unlike forms is a consideration, please specify or submit a full pattern drawing.

## TOOL INFORMATION

AØ \_\_\_\_\_

## GENERAL INFORMATION

Material Type \_\_\_\_\_

Material Thickness "T" \_\_\_\_\_

Machine Type \_\_\_\_\_

Tooling Style \_\_\_\_\_

Tooling Station \_\_\_\_\_

Dimensions filled in by \_\_\_\_\_

Approved By \_\_\_\_\_

Ø indicates DIAMETER



Holland Precision Tooling BV  
Amsterdamsstraatweg 33 - 1411 AW Naarden  
Tel.: 035 - 539 90 90 - info@hptooling.nl

